

LDA-4500



TARGET APPLICATIONS

- Desktop PC security
- Mobile PCs
- Custom applications

FEATURES

- Blue LED
- Small form factor
- Excellent image quality
- Superior ESD resistance
- Encrypted fingerprint data
- Latent print rejection
- Counterfeit finger rejection
- Rotation invariant
- Rugged
- Works well with dry, moist or rough fingerprints
- Compatible with Windows® 7, Vista, XP Professional, 2000 and Windows Server 2000, 2003, 2008

KEY SPECIFICATIONS

- Pixel resolution: 512 dpi (average x, y over the scan area)
- Scan capture area: 14.6 mm (nom. width at center) 18.1 mm (nom. length)
- 8-bit grayscale (256 levels of gray)
- Reader size (approximate): 65 mm x 36 mm x 15.56 mm
- Compatible with USB 1.0, 1.1 and 2.0 (Full Speed) specifications

PRODUCT DESCRIPTION

The LDA-4500 Fingerprint Reader is a USB peripheral perfect for individual desktop users, as well as multiple users in shared environments. Its compact design conserves desk space in enterprises, and its professional, modern appearance looks elegant

in point-of-sale environments. The LDA-4500 Reader utilizes optical fingerprint scanning technology to achieve excellent image quality, a large capture area and superior reliability. A silicone coating allows it to read a wide range of fingerprints accurately and rapidly regardless of placement angle. The high-quality metal casing resists unintentional movement.

To use, simply place a finger on the reader window and the reader quickly and automatically captures and encrypts the fingerprint image before sending it to the DigitalPersona® FingerJet™ biometric engine for verification. For superior user feedback, a red “flash” indicates that a fingerprint image has been captured.

The LDA-4500 Fingerprint Reader is designed for use with DigitalPersona’s full range of software including our authentication solutions, DigitalPersona® Pro Enterprise and DigitalPersona® Online, as well as our LDA-4500 Software Development Kits (except for the LDA-4500 SDK for Android). Whether you are an enterprise customer or a system integrator, DigitalPersona’s biometric identity verification solutions provide a natural extension to your security system and applications.

ABOUT DIGITALPERSONA, INC.

DigitalPersona offers the world’s broadest portfolio of biometrics-based identity verification solutions. Applications range from highly secure banking environments and complex government identity programs to basic point-of-sale retail systems. Our solutions verify the identity of more than 200 million authorized users worldwide and significantly reduce the risk of fraud, theft and unauthorized access. Offerings for end-users and system integrators include industry-specific software applications, complete SDKs and a full range of optical, silicon, touch, swipe and embedded readers.

LDA-4500 Reader

Optical USB Fingerprint Reader

Mechanical Specifications

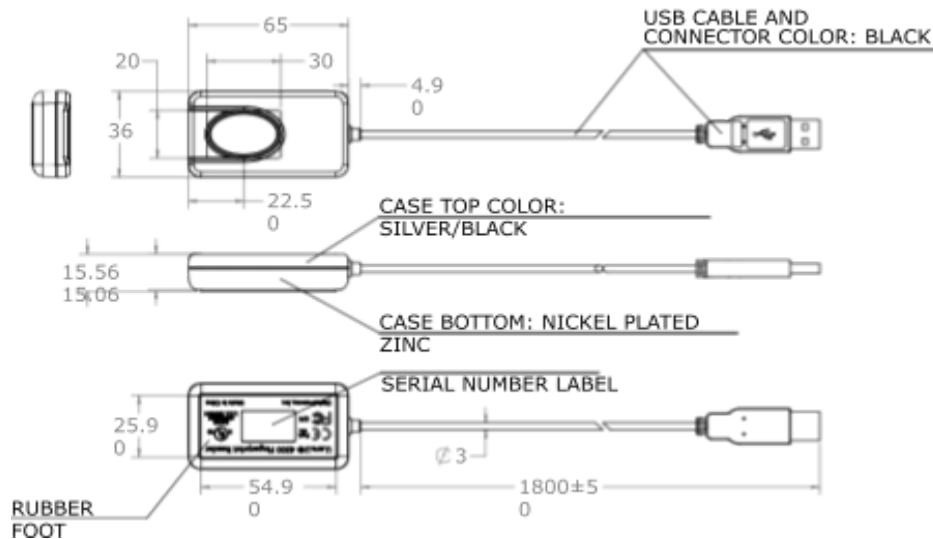

ALL DIMENSIONS ARE IN MILLIMETERS

RATINGS

Supply Voltage	5.0V ±5% supplied by USB
Supply Current—scanning	< 100 mA (Typical)
Supply Current—Idle mode	120 mA (Typical)
Supply Current—suspend mode	< 0.5 mA (Maximum)
ESD Susceptibility	>15 kV, mounted in case
Temperature, Operating	0 - 40 C
Humidity, Operating	20% - 80% non-condensing
Temperature, Storage	-10 - 60 C
Humidity, Storage	20% - 90% non-condensing
Scan Data	8-bit grayscale
Standards Compliance	FCC Class B, CE, ICES, BSMI, MIC, USB, WHQL
Weight	105 grams
Interface	USB 2.0 Full-speed High Power Device

Data subject to change without notice.